





## Food Establishment Application

Email Application to: [eh@carsoncity.gov](mailto:eh@carsoncity.gov)

Permits are **NON-Transferrable and NON-Refundable**

Carson City Health and Human Services Environmental Health Division

900 E Long St Carson City, NV 89706

Phone: 775-887-2190 ext. 80029

[Gethealthycarsoncity.org](http://Gethealthycarsoncity.org)



The information in this package is to guide the owner or builder through the submittal and approval procedures when obtaining a permit to operate a Food Establishment in Carson City. A food establishment means “any place, structure, premises, vehicle or vessel, or any part thereof, in which any food intended for ultimate human consumption is manufactured or prepared by any manner or means whatever, or in which any food is sold, offered or displayed for sale or served” per **NRS 446.020**.

- The design of all food establishments must be designed with all applicable codes, including but not limited to the: **Nevada Administrative Code 446 and the Uniform Plumbing Code**.
- In Carson City, new businesses and expansions to existing businesses will require that all applicable fees associated with the nature of the establishment be paid before a permit is issued. Please contact Carson City Business License at 108 Proctor Street, Carson City, NV. Phone: (775) 887-2105.
- Submit plans to the Building Dept: Carson (775) 887-2310 and Douglas County (775) 782-6200
- Liquor license Carson City and/or Douglas Sheriffs Office
- The permit is issued upon a passing final inspection and the annual fee is billed.

**Note:** For questions regarding **Grease Interceptors** in Carson City, please call

Carson City Environmental Control at (775) 887- 2355.

For Douglas County reach out to your Sewer Utility provider.

### Regulations for food establishments:

- Nevada Revised Statutes & Nevada Administrative Code (NAC) 446, which can be found online at <http://leg.state.nv.us/NAC/NAC-446.html>
- Carson City Municipal Code, Chapter 9, which can be found online at [www.municode.com/library/NV/Carson\\_City/Code\\_of\\_Ordinances](http://www.municode.com/library/NV/Carson_City/Code_of_Ordinances)

### Additional Documentation to be submitted for review:

- Proposed menu **MUST** be submitted with application
- For complex, at-risk processes HACCP Plans, or SOPs are required
- Food Protection Manager certificate, if applicable
- Provide Restroom Agreement and Service Depot Forms for Food Truck and Catering
- Provide detailed to scale floor plans for Food Trucks with fresh and wastewater capacity

### For Construction or New Equipment

- Manufacturer specification sheets for each piece of equipment shown on a site plan.
- Site plan showing the location of the building, location of building construction, including alleys, streets and location of any outside facilities (ex: dumpsters, patios, walkways).
- Plan drawn to scale of facility showing location of equipment, plumbing, electrical services and mechanical ventilation.

### Required Inspections:

- Carson City Health and Human Services, Environmental Health will perform inspections of all new, remodeled, changes of ownership, and converted facilities.
- You will be contacted by a Health Inspector following review.

Type of Establishment (Check as many as apply)		
Bar	Micro Market	School Cafeteria/Kitchen
Bottled Water Plant	Mobile Food Vehicle	School Culinary
Catering	Portable Bar	Support Kitchen
Child Care Kitchen	Restaurant	Vending Machine
Distributor	Retail Food Producer	Wholesale
Food Pantry	Retail Grocery	Other: _____
Food Service		

Type of Service (check as many as apply)			
Sit-down meals	Take Out	Delivery	Other: _____
Will food be transported to another location (e.g. catering, satellite kitchen, etc.)?		Yes	No
Will this food establishment be bagging ice for retail sales?		Yes	No
Will this food establishment make food to be sold to other retail food establishments?		Yes	No
NUMBER OF SEATS	Indoor _____	Outdoor _____	TOTAL SQ FT OF FOOD SERVICE _____

Describe in detail the activity of your business:

Projected Hours of Operation	
SUNDAY _____	THURSDAY _____
MONDAY _____	FRIDAY _____
TUESDAY _____	SATURDAY _____
WEDNESDAY _____	

Projected Number of Meals			<i>Not Applicable</i>
BREAKFAST _____	LUNCH _____	DINNER _____	

Construction/Renovation/New Equipment			<i>Not Applicable</i>
Name of Contractor:			
Mailing Address:			
City:		State:	Zip:
Primary Phone: ( )	Alternate Phone: ( )	Fax: ( )	
Applicable License #:			
Name of Architect/Engineer Firm:			
Primary Contact:		Email Address:	
Mailing Address:			
City:		State:	Zip:
Primary Phone: ( )	Alternate Phone: ( )	Fax: ( )	

Water/Sewer		<i>Not Applicable</i>
Source of Water: Municipal (provide the name of the water utility): _____		Well
Sewer: Municipal (provide the name of the sewer utility): _____		Septic

**Food Delivery** *Not Applicable*

Source of Delivery: \_\_\_\_\_ Unknown | Delivery: Weekly Bi-Weekly Monthly

Days of Delivery: Sunday Monday Tuesday Wednesday Thursday Friday Saturday

**Special Processes Used (Check all that Apply and INCLUDE HACCP and/or SOP)** *Not Applicable*

Acidification (sushi rice, marinara sauce, BBQ sauces)	Packaging and Labeling Food for Retail Sales
Curing (Meat, Poultry, or Fish)	Pickling
Custom Processing of Game	Reduced Oxygen Packaging (e.g. vacuum sealed packaging, cook-chill, sous vide)
Fermenting products (Sauerkraut, Kimchi, or Sausage)	Smoking for Preservation
Juice Processing and Packaging	Sprouting (seeds or beans)
Molluscan Shellfish Display Tank (e.g. oysters, clams, mussels, or scallops)	





Will time be used as the only form of public health control? Yes No

What Food?	How Long?	Location?	Standard Operating Procedure (SOP) for monitoring?
<i>(example) Sushi rice</i>	<i>4 hours</i>	<i>Line 1</i>	<input checked="" type="checkbox"/> <i>I have attached the SOP for this process</i>
			I have attached the SOP for this process
			I have attached the SOP for this process
			I have attached the SOP for this process
			I have attached the SOP for this process
			I have attached the SOP for this process
			I have attached the SOP for this process

**Cold Storage** *Not Applicable- This establishment does not store food items that require refrigeration*

Cold Storage Types				Refrigeration (# of units)	Freezer (# of units)
Reach-In	1-Door	2-Door	Multiple		
Refrigerated drawers	2-Door	4-Door	Multiple		
Sandwich Prep Table	1-Door	2-Door			
Under counter	1-Door	2-Door	Multiple		
Walk-in	Indoor	Outdoor	Display		
Cubic-feet of reach-in cold storage:				Square-feet of walk-in cold storage:	
Refrigerator storage (cubic feet):				Refrigerator storage (square feet):	
Freezer storage (cubic feet):				Freezer storage (square feet):	

**Thawing Method** *Not Applicable- This establishment does not thaw food items*

Refrigeration	Submerged under running water below 70°F	Cooked from a frozen state	Microwave as part of cooking process
			
Meat Poultry Pork Fish Shellfish	Meat Poultry Pork Fish Shellfish	Meat Poultry Pork Fish Shellfish	Meat Poultry Pork Fish Shellfish

**NO THAWING ON COUNTER**

I understand that thawing on the counters is prohibited.

\_\_\_\_\_  
(Initials)



**Hot Holding**

*Not Applicable- This establishment does not store food items that require hot holding*

Check all that apply

Hot Holding Cabinet

Oven

Steam Tray

Stove Top





Other: \_\_\_\_\_

- Explain how TCS food(s) will be maintained above 135°F during holding prior to service

**Cooling Method**

*Not Applicable- This establishment does not have food items that require cooling*

Check all that apply

Cooling Method	Shallow pan	Ice Paddle	Ice Bath	Rapid Chill Equipment (e.g. blast chiller)	Volume Reduction (e.g. quartering)
<i>*Food <b>MUST</b> be cooled to 41°F within 6 hrs</i>					
<i>Example: Pinto Beans</i>	<input checked="" type="checkbox"/>	<input checked="" type="checkbox"/>	<input checked="" type="checkbox"/>	<input type="checkbox"/>	<input checked="" type="checkbox"/>
Solid Food: Roast(s), Turkey, Steaks					
Soft, Thick Foods: Beans, Rice, Gravy, Soups, Sauce					
Bake/Boiled Potatoes					
Pasta					
Deli Salads (Tuna/Chicken)					
Other: _____					

**Reheating**

*Not Applicable- This establishment does not have food items that will need reheating*

- How will TCS food that is cooked, cooled, and reheated for hot holding be reheated so that all parts of the food reach a temperature of at least 165°F for 15 seconds? Indicate the type and number of units for reheating foods.

**Food Handling Procedures**

Explain handling procedures for the following food categories. Describe the process from receiving to service.

**Ready-to-Eat Food**

*Not Applicable*

These are edible without additional preparation types of food, e.g. produce, salads, sandwiches, raw molluscan shellfish, etc.

Will ingredients for cold ready-to-eat foods be pre-chilled before being mixed and/or assembled?      Yes      No- see below

- If No was marked explain below how ready-to-eat foods will be cooled to 41°F

Will all produce be washed on-site prior to use?      Yes      No

Is there a location for washing produce (e.g. prep sink, etc.)?      Yes      No

Will disposable gloves, utensils, and/or food grade paper be used to prevent handling of ready-to-eat foods?      Yes      No

**Meat/Poultry Handling**

*Not Applicable*

- Describe the procedure for minimizing the length of time TCS food will be kept in the temperature danger zone (41°F-135°F) during preparation (e.g. small batches, made to order, etc.).
- How will food arrive (e.g. frozen, fresh, packaged, etc.)?
- What equipment will be used to prepare, handle, and cook food? (match to equipment schedule provided)

**Seafood Handling**

*Not Applicable*

- Describe the procedure for minimizing the length of time TCS food will be kept in the temperature danger zone (41°F - 135°F) during preparation (e.g. small batches, made to order, etc.).
- How will food arrive (e.g. frozen, fresh, packaged, etc.)?
- What equipment will be used to prepare, handle, and cook food? (match to equipment schedule provided)

**Dry Storage** *Not Applicable*

How many square feet of dry storage shelf space? \_\_\_\_\_

- Explain where dry goods will be stored and identify the plan page(s) and location

**Warewashing Equipment** *Not Applicable*

**Manual Warewashing (e.g. 3 compartment sink with drain boards)** *Not Applicable*

What type of sanitizer will be used? \_\_\_\_\_

Does the largest pot or pan fit into each compartment of the sink? Yes      No

- Describe the cleaning procedure if the largest pot or pan doesn't fit in the sink

**Mechanical Warewashing (e.g. dishwasher, glass washer, etc.)** *Not Applicable*

Is a warewashing machine used?    Yes    Manufacture & model: \_\_\_\_\_    No

What type of sanitizer will be used?      Hot water (180°F)      Chemical: \_\_\_\_\_

Does the largest pot or pan fit into the mechanical warewashing? Yes      No

- Describe the cleaning procedure if the largest pot or pan doesn't fit in mechanical warewashing

- Describe how cleaning will happen if mechanical warewashing fails

**Food Contact Surface/Sanitation Plan**

Bucket                      Spray Bottle                      Other: \_\_\_\_\_

What type of Sanitizer will you be using? \_\_\_\_\_

What type of test strips will you be using for each type of sanitizer in the facility? \_\_\_\_\_

**Tableware** *Not Applicable*

Single-use(Disposable)                      Reusable (Food Grade, Washable)                      Both

**Hand-washing**

Will splash guards be used?      Yes                      No      |      What hand soap will be used? \_\_\_\_\_

How will paper towels be dispensed? \_\_\_\_\_

- Describe the number, and location of all hand-washing sinks

**Required Signage (Initial each signage needed)**

\_\_\_\_\_ Employees Must Wash Hands signage (in restrooms)      \_\_\_\_\_ No Smoking signage  
 \_\_\_\_\_ Handwash Only signage (handwashing sinks)      \_\_\_\_\_ Alcohol Health Advisory signage

**Plumbing Cross Connections (sewer) Sewage Disposal**

Check all that apply

Fixture	Indirect	Direct	N/A
3 compartment sink			
Bain-Marie / Kettle / Steamer			
Beverage lines (soda guns)			
Coffee / Espresso machine			
Dipper wells			
Dishwasher			
Glass washer			
Hand sink			
Hose connections			
Ice machine			
Ice storage bin			
Mop sink			
Prep sink			
Refrigeration condensation lines			
Rethermalizer			
Soda machine			
Walk-in floor drain			
Wok range			
Other _____			

\*Sewage Disposal:

**Air Gap:** is the unobstructed vertical space between the water outlet and the flood level of a fixture.

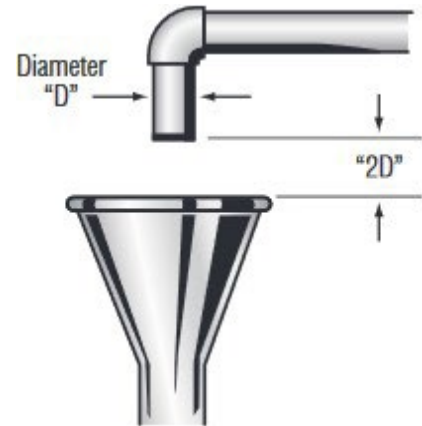

A direct connection may not exist between the sewerage system and any drains originating from equipment in which food, portable equipment, or utensils are placed. These types of equipment drains must be air gapped.

**Mop/Utility Sink** *Not Applicable*

Is a separate mop storage area provided? Yes No

• Describe the number, size, type, and location of all mop sinks



**“Y” or any other valves are not allowed on mop sinks**

• Describe your process to clean and store mops

**Refuse and Recyclables**

Will refuse be stored inside? Yes No Where: \_\_\_\_\_

How will refuse be disposed? Dumpster Compactor Other: \_\_\_\_\_

Describe location for storage of recyclables (e.g. cooking grease, cardboard, glass, etc.)

**Employee Accommodations**

Explain where employee personal items are stored

**Insect and Rodent Control**

What protection is provided on all outside doors? Self-closing door Air Curtain Screen Door

What protection is provided on windows? Self-closing Air Curtain Screening

Is commercial pest control used at this food establishment? Yes No

Who is providing pest control? \_\_\_\_\_ How often is pest control servicing? \_\_\_\_\_

**Poisonous or Toxic Materials**

Describe the location for storage of poisonous / toxic materials (e.g. chemicals, sanitizers, etc):

<b>Mobile Food Truck/Trailer/Unit</b>	<i>Not Applicable</i>
---------------------------------------	-----------------------

What county are you wanting to be permitted for?	Carson City	Douglas County	Both
--	-------------	----------------	------

<b>Acknowledgement (initial all spots)</b>
--

- I understand a mobile food unit cannot provide seating of any kind to guests during operation.
- I understand a mobile food unit can operate for a maximum of FOUR (4) HOURS if not attending a temporary event where there is restroom access to staff and guests.
- If I will be operating for more than one (1) hour, and no more than four (4) hours, then I will submit a restroom agreement form with a business that can provide restroom access.
- I will not park in the right-of-way on any public roads without prior consent from Carson City.
- I will not operate on private property without prior approval from the property owner.
- I WILL submit Temporary Event Applications for all events that I attend.
- I will not store the mobile unit on residential property at any time, and I have an overnight storage location for this mobile unit that complies with relevant zoning ordinances.
- I will store food at a service depot/commissary and provide a service depot form.
- I will be using ONLY ANSI certified commercial equipment.
- All the surfaces in the mobile food unit will be smooth, cleanable, and non-porous.
- I will submit a floorplan/diagram of the mobile food unit and where all equipment and washing stations are located.
- I will dispose of wastewater and garbage at appropriate facilities.

<b>Proposed Locations (must have agreement with Property Owner)</b>
---

Location 1:	Location 2:	Location 3:
-------------	-------------	-------------

Mobile Unit Storage Location:
-------------------------------

<b>Proposed Itinerary</b>
---------------------------

	Time and Location	Time and Location	Time and Location	Time and Location
<b>Sunday</b>				
<b>Monday</b>				
<b>Tuesday</b>				
<b>Wednesday</b>				
<b>Thursday</b>				
<b>Friday</b>				
<b>Saturday</b>				

**FINAL STATEMENT and SIGNATURE**

*I hereby certify that all the above information is correct, and I fully understand that any deviation from the above approval without prior permission from this Health Regulatory Office may nullify this approval. Approval of these plans and specifications by this Health Regulatory Authority DOES NOT indicate compliance with any other code, law or regulation that may be required by federal, state or local agency. It further DOES NOT constitute endorsement or acceptance of the completed establishment, including but not limited to the structure or equipment. A pre-opening inspection of the establishment with the equipment will be necessary to determine if it complies with the State of Nevada and/or Carson City Municipal Codes as applicable governing food service establishments.*

Signature(s): \_\_\_\_\_ Date: \_\_\_\_ / \_\_\_\_ / \_\_\_\_